

### Features

- Moderate Speed, CMOS Technology (25 nS)
- Complementary Outputs
- High Drive Current Capability ( $\pm 50$  mA)
- Low Current Consumption
- Plastic SOIC Body for SMT Applications
- Tape and Reel Packaging Available
- Lead-Free SOIC-8 Package
- 100% Matte Tin Plating over Copper
- Halogen-Free “Green” Mold Compound
- 260°C Reflow Compatible
- RoHS\* Compliant Version of DR65-0003

### Description

M/A-COM's MADR-007097-000100 is a SPDT driver used to interface between TTL logic signals and PIN diode based microwave switches. High-speed analog CMOS technology is used to achieve low power consumption at moderate speeds. Low output resistances allow it to develop high output current spikes to ensure fast switching speeds. The complementary output stages are structured so it can be used as an inverting or non-inverting driver for SPST switches, or as a single input, complementary driver for SPDT switches. The monolithic die is packaged in a SO-8, plastic surface mount package and is available in tape and reel packaging for high volume applications. The MADR-007097-000100 driver is ideally suited for driving M/A-COM's line of HMIC switches.

### Functional Block Diagram

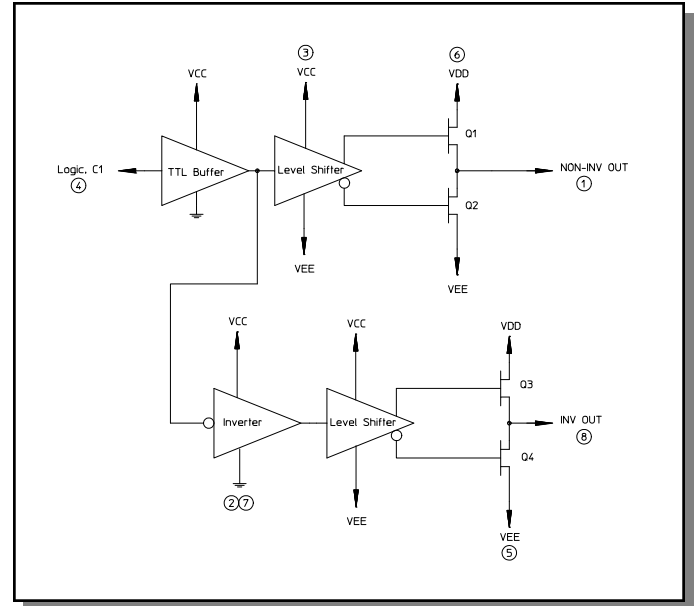

### Ordering Information

Part Number	Package
MADR-007097-000100	Bulk Packaging
MADR-007097-0001TR	1000 piece reel

Note: Reference Application Note M513 for reel size information.

### Pin Configuration

Pin No.	Function	Pin No.	Function
1	NON-INV OUT	5	VEE
2	GND	6	VDD
3	VCC	7	GND
4	C1 (TTL Logic)	8	INV OUT

\* Restrictions on Hazardous Substances, European Union Directive 2002/95/EC.

**Electrical Specifications:  $T_A = +25^\circ\text{C}$ ,  $+V_{CC} = +V_{DD} = +5.0\text{V} \pm 5\%$ ,  $V_{EE} = -5.0\text{V} \pm 5\%$ ,  $Z_0 = 50\Omega$**

Parameter	Test Conditions	Units	Min	Typ	Max
Switching Speed <sup>1</sup> Delay Rt/Ft	Spike current into 10 ohm load 50 % TTL to 90% 10%-90%; 90%-10%	ns	—	25	35
		ns	—	2	5
PRF	50% duty cycle	MHz	DC	—	5
Output Voltage Drop, No Load	With reference to supply voltage	V	—	—	0.25
DC Output Current Peak Spike Output Current	Load Dependant Spiking Capacitor in Circuit	mA	—	±30	±50
		mA	—	±150	±200
Output Stage on Resistance	Positive Output FET, Qp Negative Output FET, Qn	$\Omega$	—	15	20
		$\Omega$	—	10	15
Quiescent Supply Currents	+5V -5V	mA	—	—	1.5
		mA	—	—	.2
TTL Levels	Logic "0" @ 20 $\mu\text{A}$ sink current Logic "1" @ 20 $\mu\text{A}$ source current	V	0	—	.8
		V	2.0	—	5.0
Package Dissipation	—	mW	—	—	200

1. Decoupling capacitors (.01  $\mu\text{F}$ ) are required on power supply lines.

### Absolute Maximum Ratings <sup>2,3</sup>

Parameter	Absolute Maximum
VCC	$-0.5\text{V} \leq V_{CC} \leq +7.0\text{V}$
VDD	$-0.5\text{V} \leq V_{DD} \leq V_{CC}$
VEE	$-7.0\text{V} \leq V_{EE} \leq +0.5\text{V}$
C1 (TTL Input Voltage)	$-0.5\text{V}$ to $V_{CC} + 0.5\text{V}$
Operating Temperature	$-40^\circ\text{C}$ to $+85^\circ\text{C}$
Storage Temperature	$-65^\circ\text{C}$ to $+125^\circ\text{C}$

- Exceeding any one or combination of these limits may cause permanent damage to this device.
- M/A-COM does not recommend sustained operation near these survivability limits.

### Handling Procedures

Please observe the following precautions to avoid damage:

### Static Sensitivity

Silicon Integrated Circuits are sensitive to electrostatic discharge (ESD) and can be damaged by static electricity. Proper ESD control techniques should be used when handling these devices.

### SPDT Microwave Switch with Driver

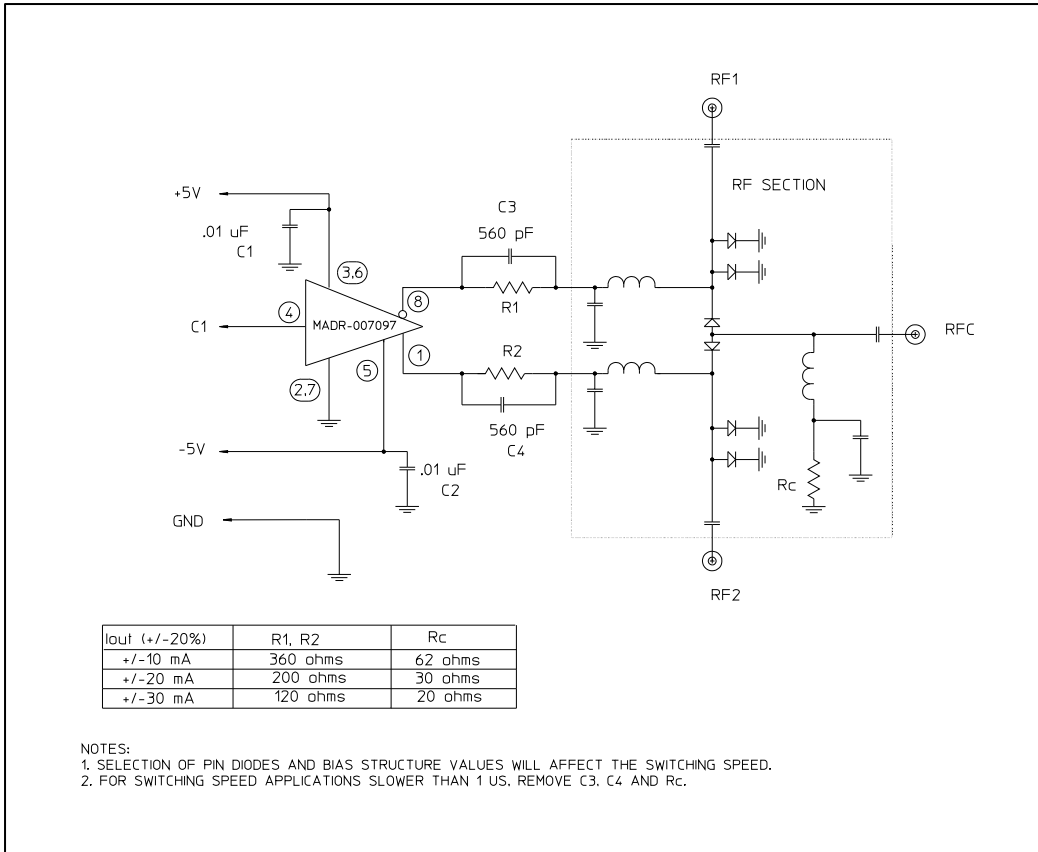

### Lead-Free, SOIC-8<sup>†</sup>

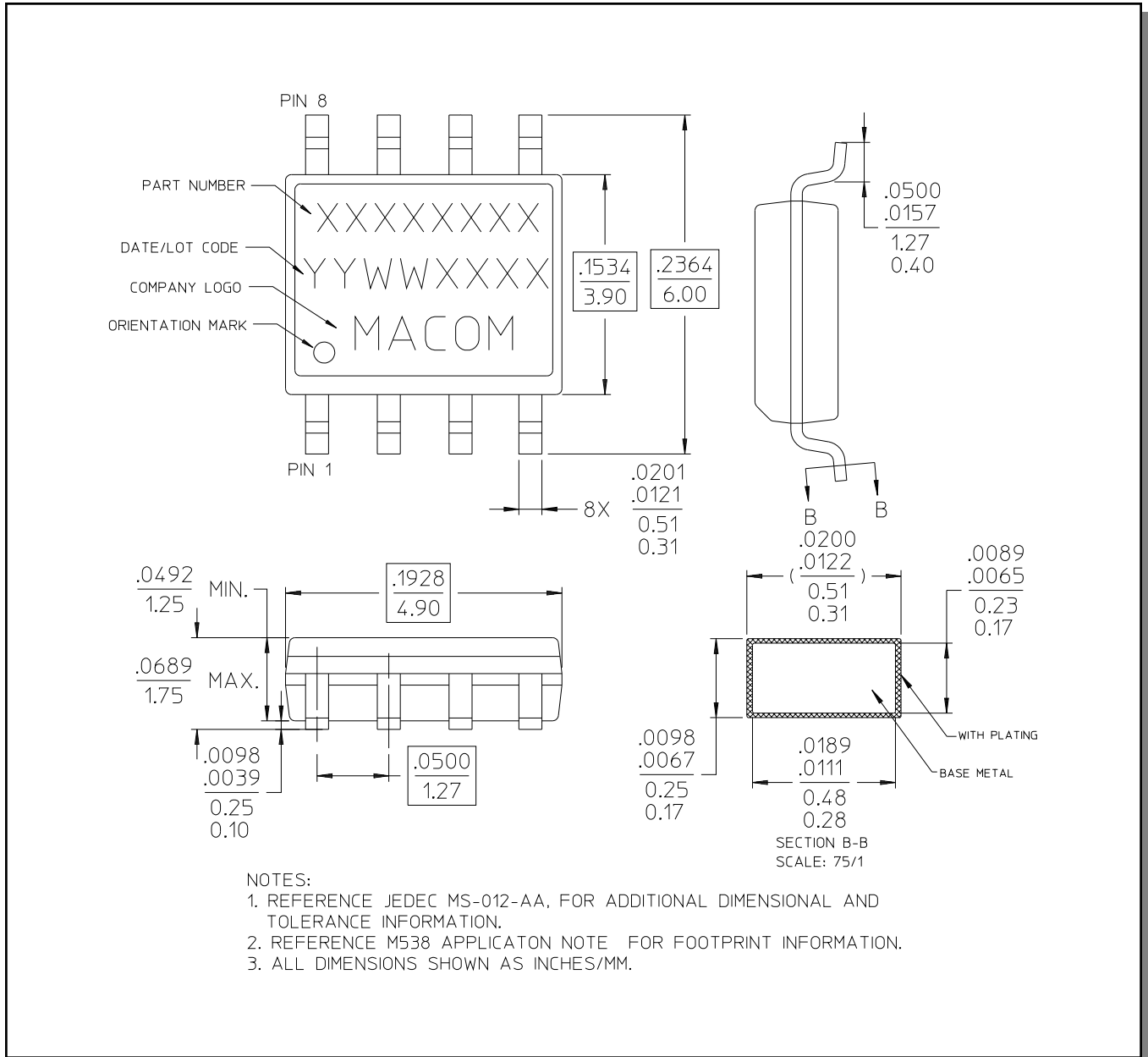

<sup>†</sup> Reference Application Note M538 for lead-free solder reflow recommendations.